

Gewindemutter
Gewindetyp muss
bestimmt werden

Screw-nut
Type of tread must
be determined

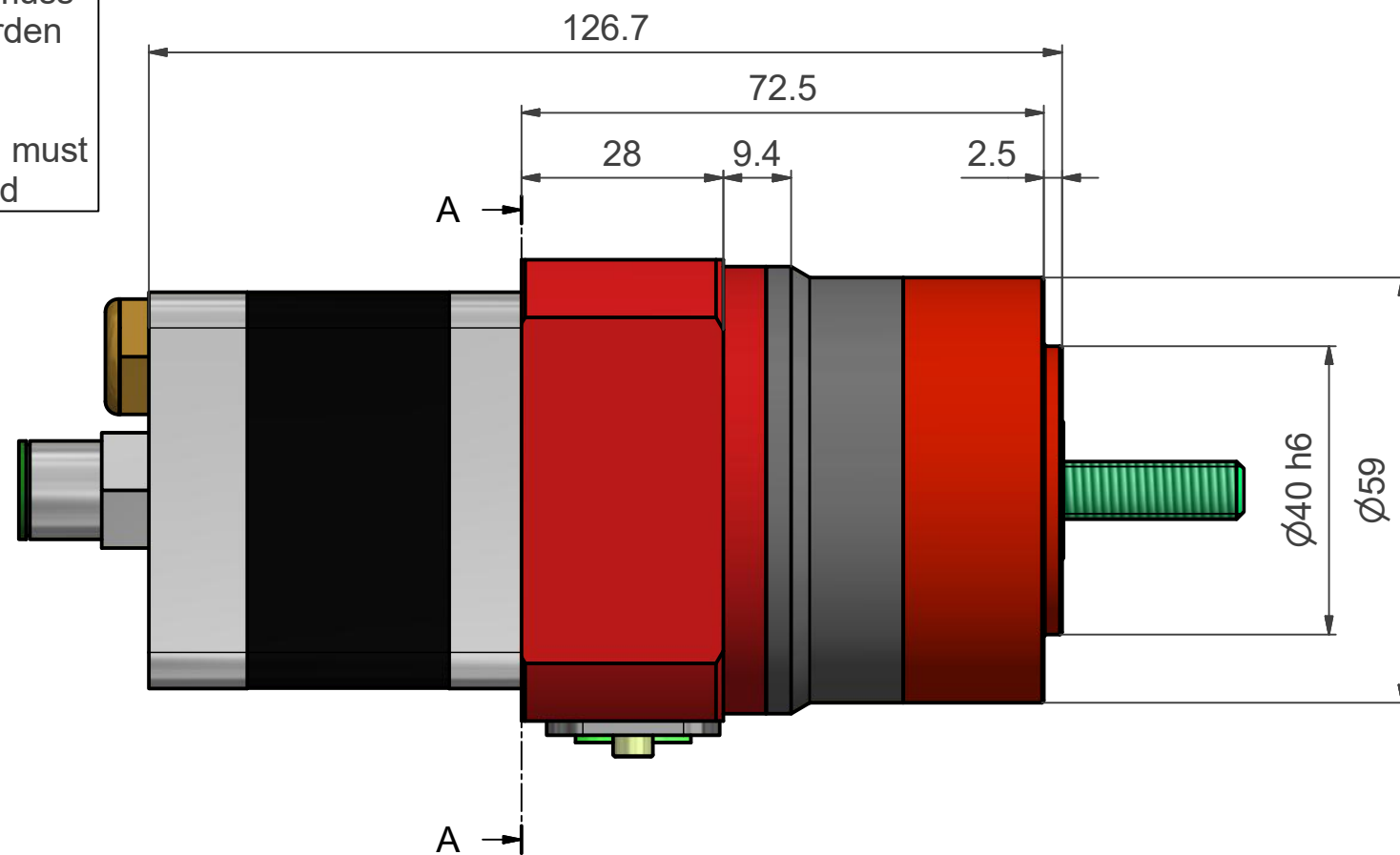

Schnitt A-A (1:1)

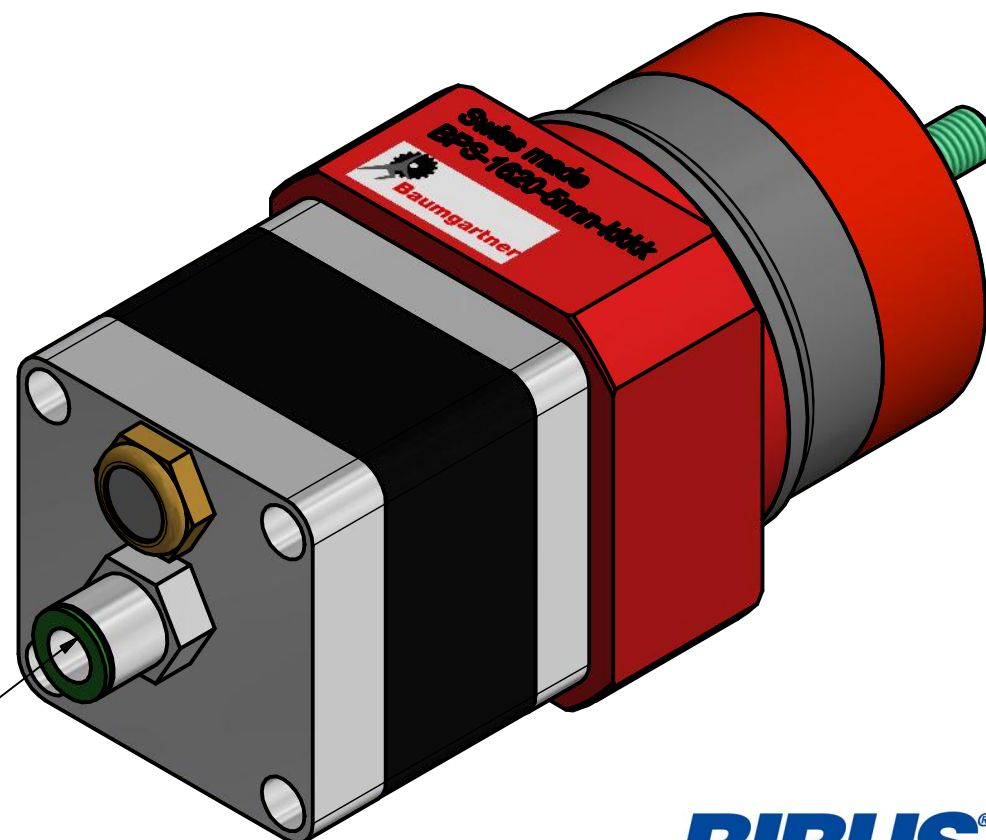
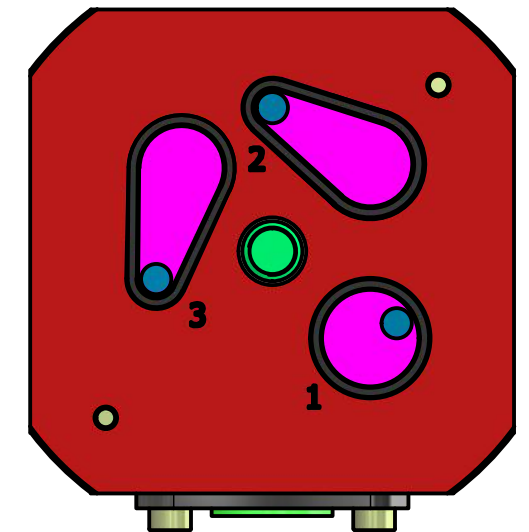

Option Spindel
Gewindetyp, Länge und ev.
Endenbearbeitungen müssen
bestimmt werden

Option spindle
Type of thread, length and end
machining must be determined

für Schlauch Ø8 mm
for hose Ø8mm

Gegenstand Schrittmotor BPS-1620-MX-SRxx	Massstab	Gezeichnet	11.01.2018	rsc
	1 : 1	Geprüft		
		Gesehen		
 Baumgartner Maschinenbau AG Gewerbestrasse 11, Lätti 3053 Münchenbuchsee Tel +41 (0)31 868 44 45 Fax +41 (0)31 868 44 40 www.baumtech.ch	Nummer	Blatt 1 von 1	Format	
	500-16-355		A3	