

In dieser Lage kann die Position der Passfedernut zum Bohrbild $\pm 1,5^\circ$ abweichen
In this situation can the keyway position varying $\pm 1,5^\circ$ to the drilling pattern

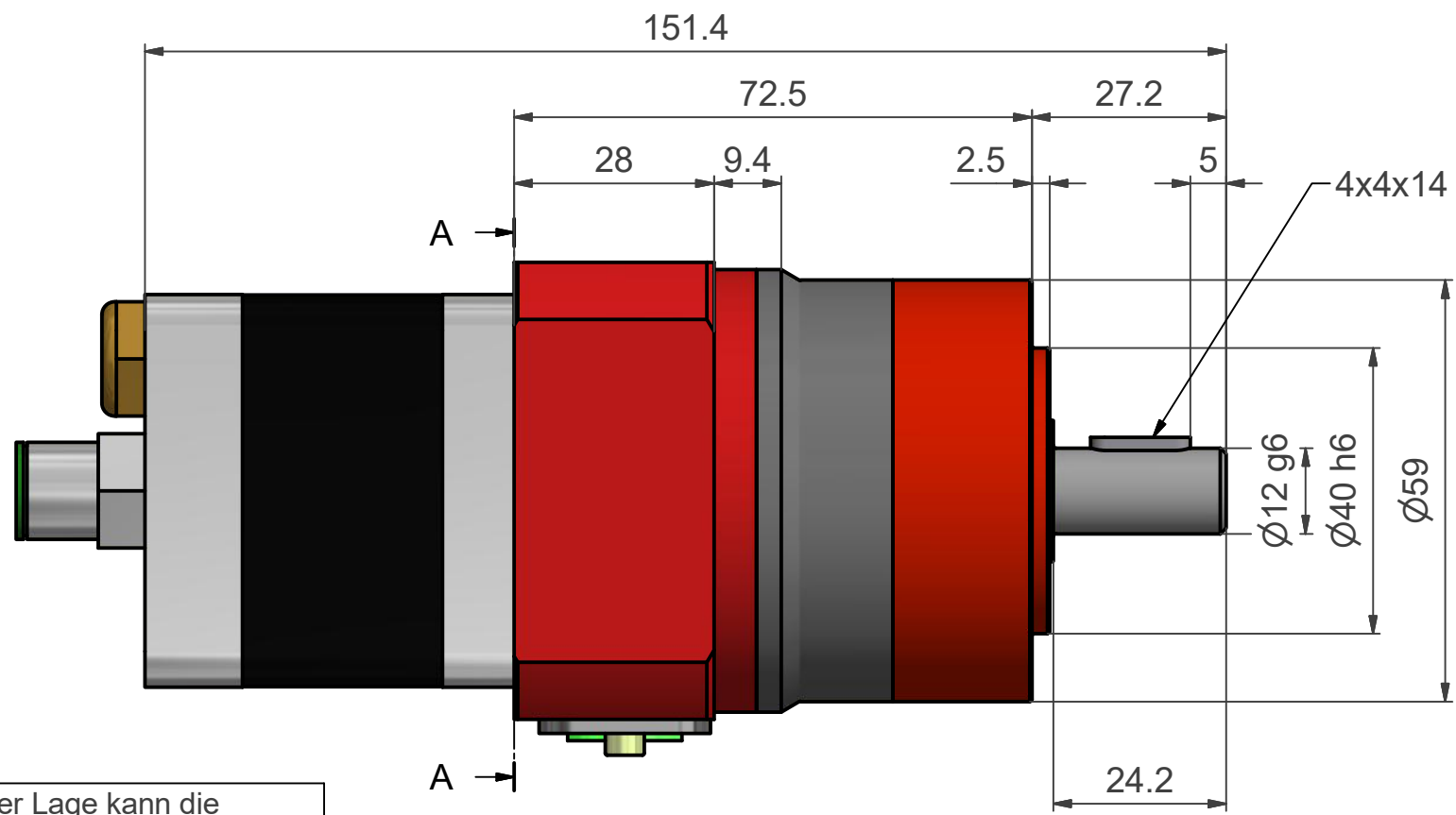

Schnitt A-A (1:1)

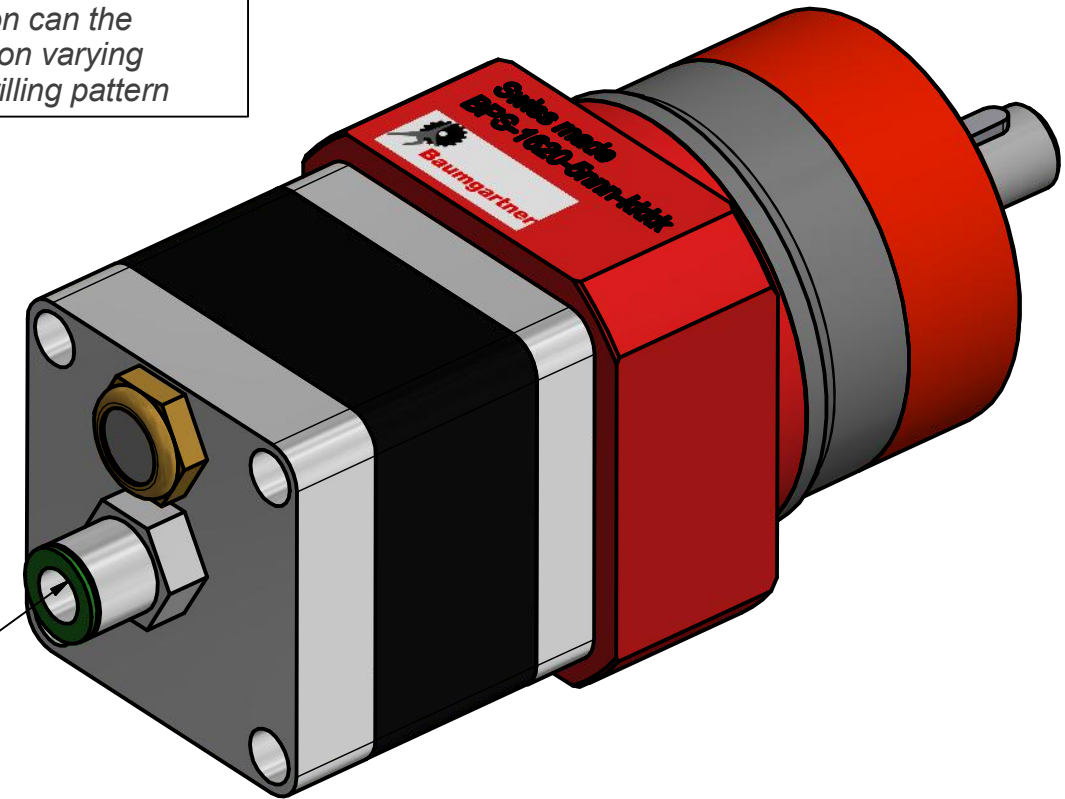
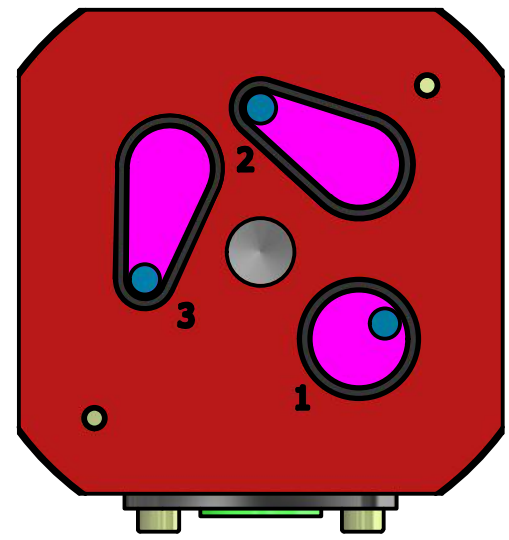

für Schlauch $\varnothing 8$ mm
 for hose $\varnothing 8$ mm

Gegenstand Schrittmotor BPS-1620-MX	Massstab	Gezeichnet	10.01.2018	rsc
	1 : 1	Geprüft		
		Gesehen		
 Baumgartner Maschinenbau AG	Gewerbestrasse 11, Lätti 3053 Münchenbuchsee Tel +41 (0)31 868 44 45 Fax +41 (0)31 868 44 40 www.baumitech.ch		Nummer 500-16-353	Blatt 1 von 1 Format A3