

In dieser Lage kann die Position der Passfedernut zum Bohrbild $\pm 1,5^\circ$ abweichen
In this situation can the keyway position varying $\pm 1,5^\circ$ to the drilling pattern

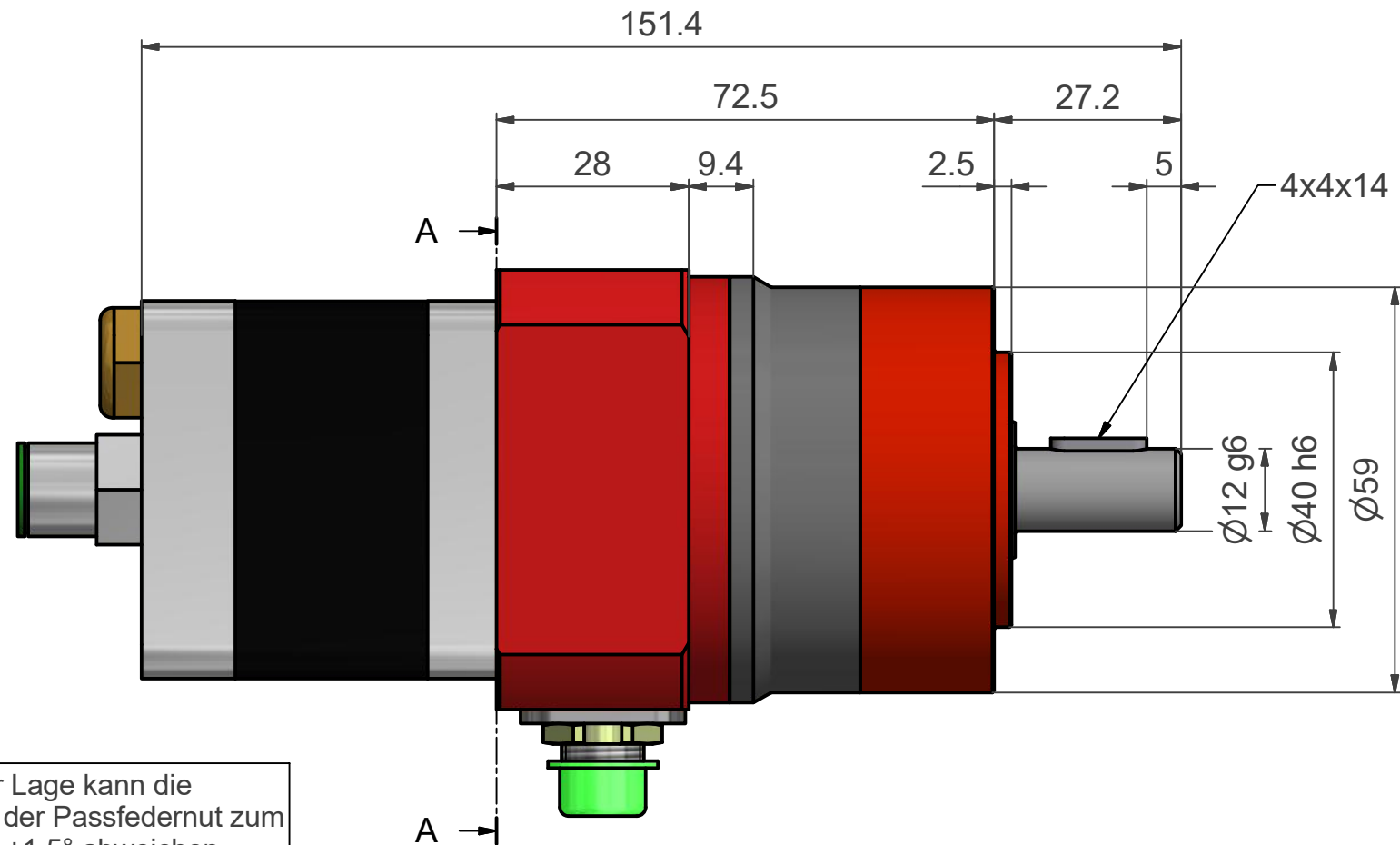

Schnitt A-A (1:1)

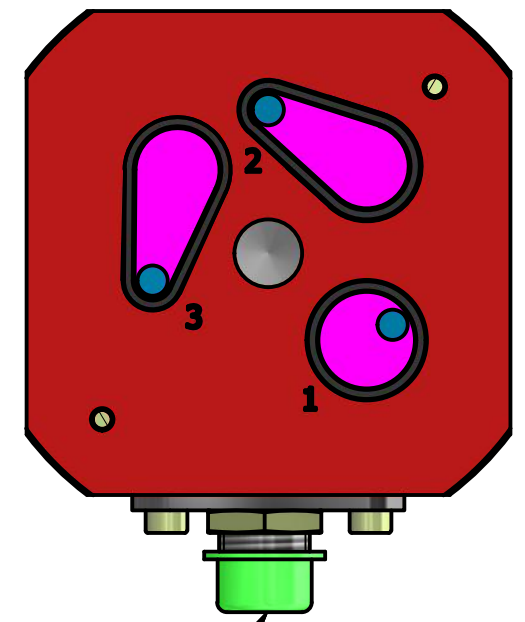

Sensoreinheit:
Anschluss über 5-Pol Stecker M12x1

Sensor unit:
Connection with 5-Pin connector M12x1

für Schlauch $\varnothing 8$ mm
for hose $\varnothing 8$ mm

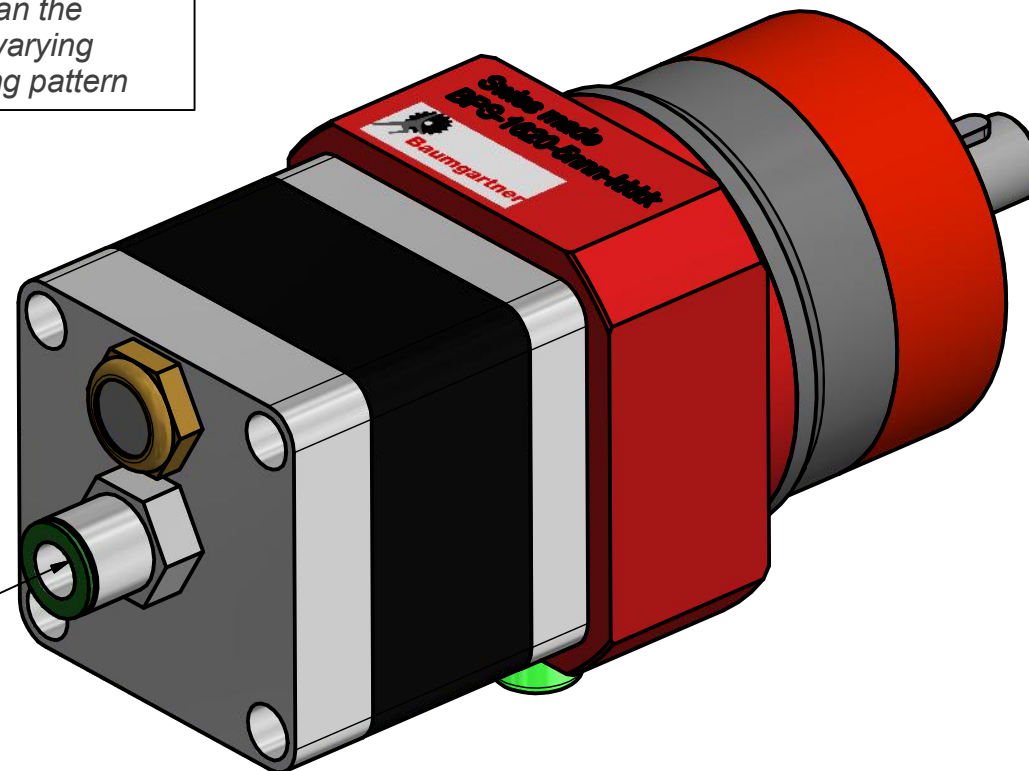

Gegenstand Schrittmotor BPS-1620-S5-MX	Massstab	Gezeichnet	10.01.2018	rsc
	1 : 1	Geprüft		
		Gesehen		
 Baumgartner Maschinenbau AG Gewerbestrasse 11, Lätti 3053 Münchenbuchsee Tel +41 (0)31 868 44 45 Fax +41 (0)31 868 44 40 www.baumtech.ch	Nummer	Blatt 1 von 1		Format
	500-16-314f			A3