

In dieser Lage kann die Position der Passfedernut zum Bohrbild  $\pm 1,5^\circ$  abweichen  
 In this situation can the keyway position varying  $\pm 1,5^\circ$  to the drilling pattern

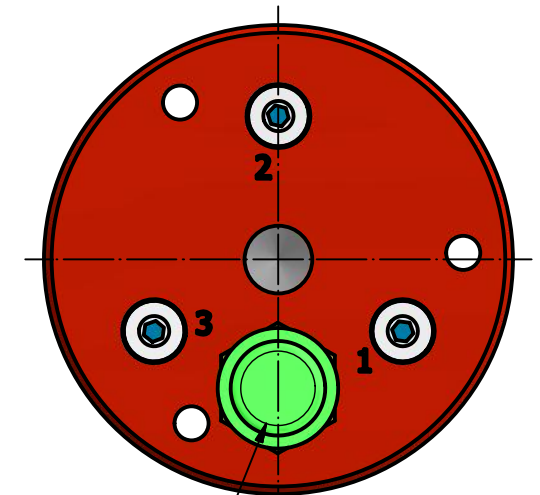

Sensoreinheit:  
Anschluss über 5-Pol Stecker M12x1  
  
Sensor unit:  
Connection with 5-Pin connector M12x1

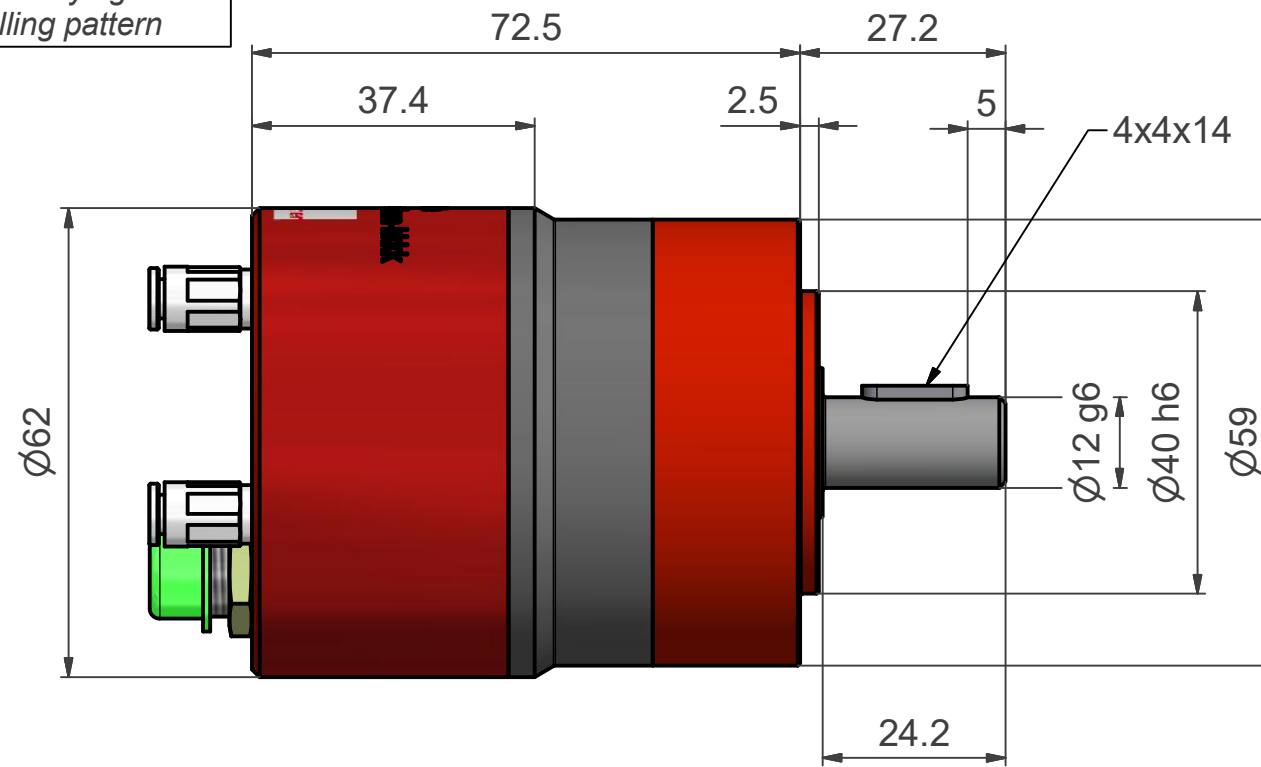
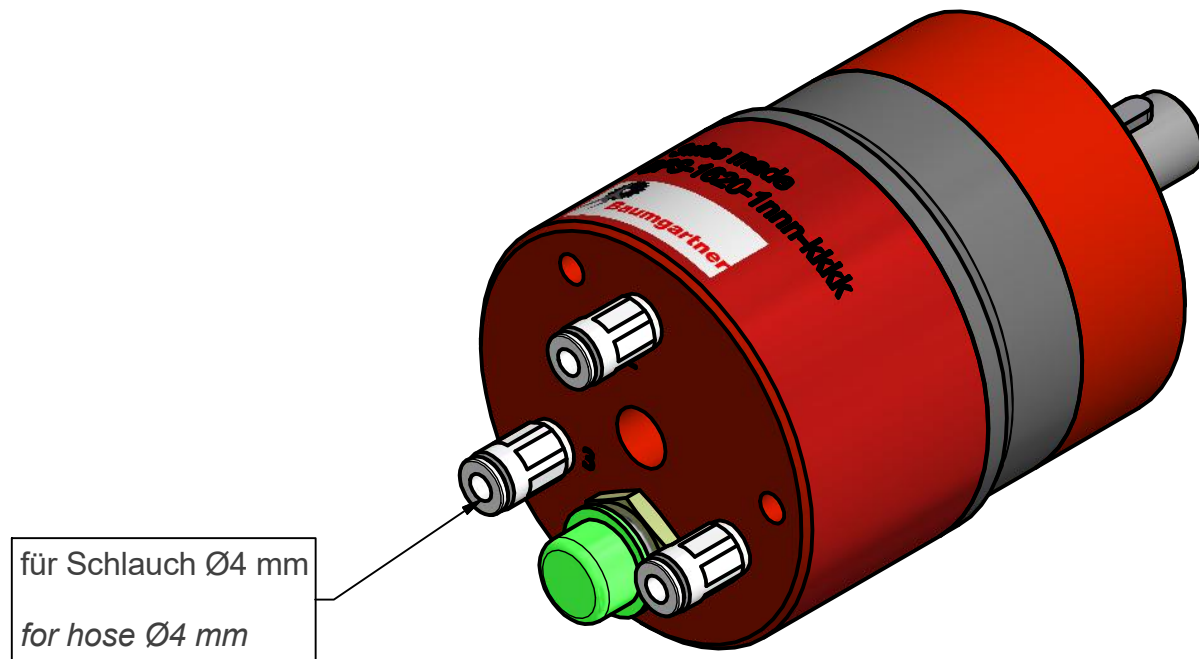

für Schlauch Ø4 mm  
for hose Ø4 mm

Gegenstand Schrittmotor BPS-1620-S5	Massstab	Gezeichnet	21.12.2017	rsc
	1 : 1	Geprüft		
		Gesehen		
 Baumgartner Maschinenbau AG Gewerbestrasse 11, Lätti 3053 Münchenbuchsee Tel +41 (0)31 868 44 45 Fax +41 (0)31 868 44 40 www.baumitech.ch	Nummer	Blatt 1 von 1		Format
	500-16-310e			A3