

In dieser Lage kann die Position der Passfedernut zum Bohrbild $\pm 1,5^\circ$ abweichen
In this situation can the keyway position varying $\pm 1,5^\circ$ to the drilling pattern

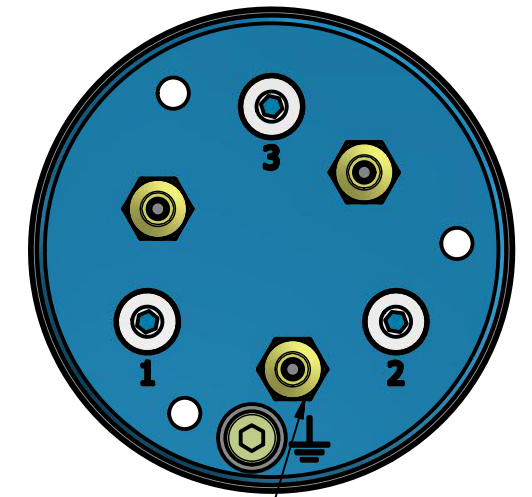

Betrieb mit Sensoren:
 Anschluss 3 Stk Kabel (Länge 5 m)
Operating with sensors
 Connection with 3 cables (length 5 m)

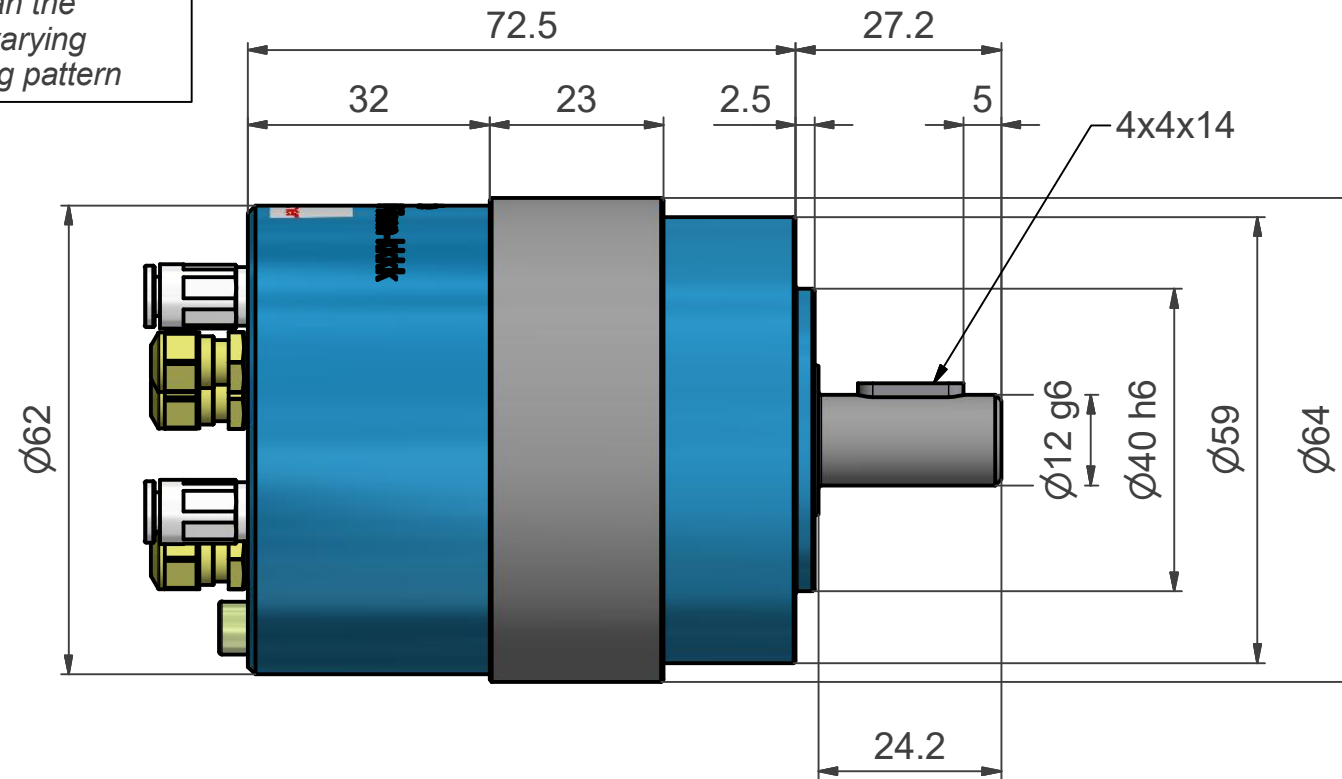
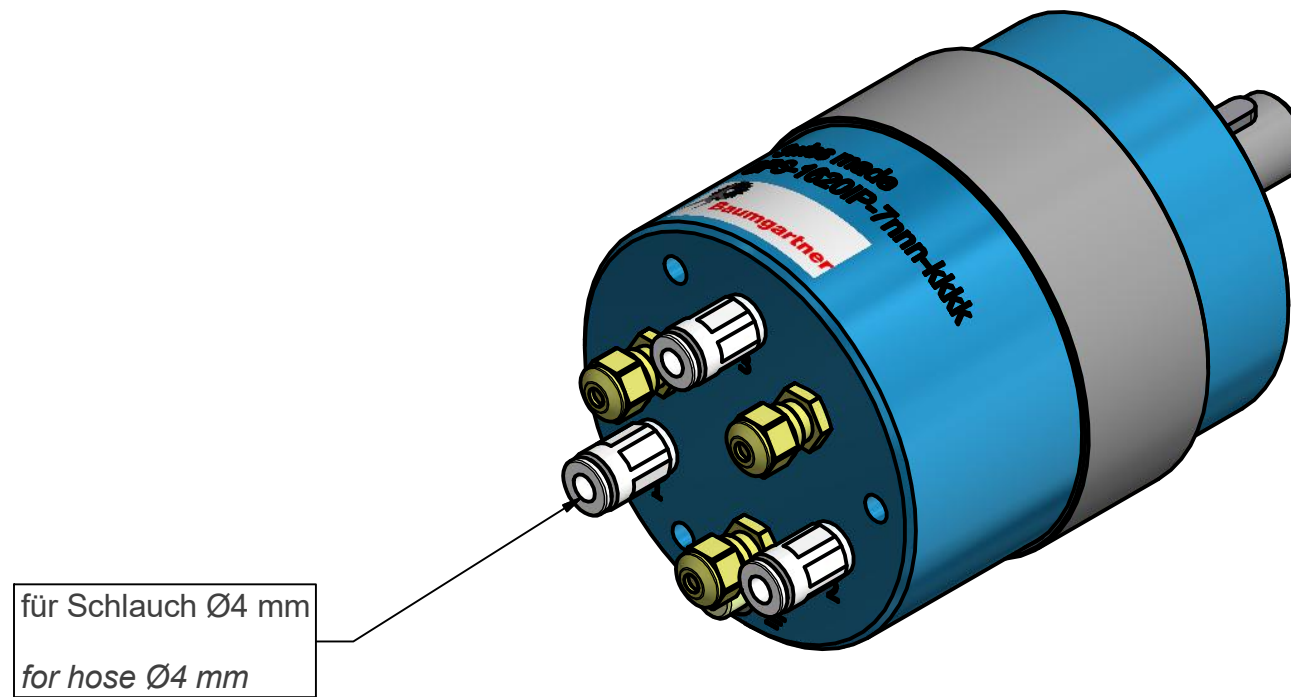

für Schlauch Ø4 mm
 for hose Ø4 mm

Gegenstand Schrittmotor BPS-1620IP-SA	Massstab	Gezeichnet	12.01.2018	rsc
	1 : 1	Geprüft		
		Gesehen		
Nummer	Blatt 1 von 1		Format	
500-16-361			A3	